

# History of wireless local area networks (WLANs) in the unlicensed bands

Kevin J. Negus and Al Petrick

Kevin J. Negus is based at Camp Ventures, Hyattville, Wyoming, USA. Al Petrick is based at Jones-Petrick Associates, Orlando, Florida, USA.

## Abstract

**Purpose** – Using a brief history of the development of WLAN standards and products this paper seeks to explain how unlicensed spectrum regulations by the Federal Communications Commission (FCC) have affected the industry.

**Design/methodology/approach** – The paper's approach is one of personal experience.

**Findings** – In general, the FCC's initiative to create an "unlicensed commons" for various forms of wireless communication applications has been the key enabler of today's multi-billion dollar per year WLAN industry. In particular, certain regulatory decisions over the past 25 years regarding these bands have had profound, generally beneficial but sometimes unexpected influence on the WLAN industry.

**Originality/value** – The paper attempts to document these inflection points and their impacts on WLANs as well as to provide some insight as to how future evolutions of the unlicensed spectrum regulations can best enable optimal usage of this valuable spectrum.

**Keywords** Local area networks, Wireless, Technical regulations

**Paper type** Research paper

## 1. Introduction

The wireless local area network (WLAN) is today a ubiquitous device often taken for granted as a default interface for networked devices by users and manufacturers alike. But not very long ago, it was most definitely not so. Rewind the clock ten years back to 1998 and not only are there bitter technical and business consortia differences on WLAN approaches, but there is extreme skepticism and variation in opinion as to how, or even if, WLANs can ever become a mainstream network interface. The WLAN of that day appeared to lack both the throughput of the wired local area network (such as 10/100 Ethernet LAN) and the coverage of the cellular network (which was supposed to be "imminently" upgrading to Mb/s data performance). The WLAN to that point had largely evolved as a slow and unreliable emulation of the wired LAN, only without the wire. And as such the products and standards largely envisioned the end application for WLAN as a replacement for wired LAN in enterprise or campus environments where mobile users would roam with their networked personal computers (PCs).

In the early 1990s WLANs found almost no success in selling to enterprise or campus environments as wired LAN replacements or enablers of mobility. The WLAN products of that day were far too slow, too expensive, too bulky, and too power hungry. Furthermore, mobile network connectivity was simply not yet a killer application. The "survivor" companies of that age were the ones who focused on adapting WLAN technology to specialty niches such as retailing, hospitality, and logistics. Organizations that went after the "big" market of enterprise networking, and there were many that did, either went bankrupt or became largely scaled back divisions of large companies.

Received 13 September 2008  
Revised 29 January 2009  
Accepted 2 June 2009

The authors thank Mike Marcus for the information available at his web site: [www.marcus-spectrum.com](http://www.marcus-spectrum.com) They also appreciate the help of Henry Goldberg, Juan Grau, David King, Jim Zyren and Vic Hayes in checking various facts in this work.

An earlier version of this paper was presented at "The Genesis of Unlicensed Wireless Policy", an Information Economy Project Conference, George Mason University School of Law, 4 April 2008.

By the middle of the 1990s the WLAN industry had mainly consolidated into four players, Proxim, Symbol, Lucent (the former NCR WLAN division) and Aironet (then still part of Telxon). And silicon suppliers such as Harris Semiconductor, AMD and Hewlett-Packard first started to exert influence on the industry with low-cost chipsets. The crucial PC Card form factor for laptop computers was achieved and with it came moderate commercial success especially by products such as Symbol's "Spectrum24", Lucent's "WaveLAN", and Proxim's "RangeLAN2" in certain markets such as healthcare and education.

But in the late 1990s the first significant market opportunity for WLANs emerged and it was quite unlike what the WLAN industry to date had largely envisioned. The opportunity was the sharing of a broadband internet connection within the home amongst multiple networked devices such as PCs initially, but inevitably also voice over internet protocol (VoIP) phones, gaming consoles, media streamers and home automation appliances. Consumers, not enterprise IT managers, became the ones to choose what WLAN technology and products would achieve the de facto standard for the decade to follow.

And consumers certainly did have some choices in those days. There were multiple variants of IEEE 802.11, HomeRF, and several proprietary individual company offerings. Eventually one IEEE 802.11 variant – 802.11b – became the dominant standard under the more consumer friendly name of "Wi-Fi®" but not without bitter competition from HomeRF and plenty of distraction from other technologies such as 802.11a, HIPERLAN, Bluetooth and Ultra wideband (UWB). It was also in this time period that the driving force within the industry moved from the equipment manufacturers to the silicon suppliers. Atheros, Broadcom, Intel, Intersil, Agere, Marvell, and others became the dominant force in the evolution of standards and technology much more so than, for example, Proxim or Symbol, or even Cisco (Aironet). Moore's Law applied to WLAN chipsets brought us ever increasing performance and ever decreasing costs as Wi-Fi-compatible products moved down a roadmap from 802.11b to 802.11g and now 802.11n. The Wi-Fi market has become the second largest wireless communications market in the world (behind only cellular telephony) and for 2008 is projected to sell 450 million units and approach 1 billion units by 2010.

While the above is an accurate, though extraordinarily abbreviated, history of the evolution of the WLAN industry, it completely ignores the subject of how unlicensed band spectrum regulations have influenced this industry. This influence of spectrum regulation upon WLAN standards and technology and to a lesser extent the return influence of the latter upon the former, will now be the focus of the bulk of this paper. In particular, six major decisions by the FCC over the past 25 years will be considered – in chronological order they are:

1. The original rules for unlicensed operation in the industrial, scientific and medical (ISM) bands.
2. The early revisions for frequency hopping bandwidth and direct sequence processing gain.
3. The U-NII process to open up additional 5GHz spectrum for digital modulation systems.
4. The acceptance of Harris' 8-chip MBOK as permissible under direct sequence rules.
5. The proceeding to allow wider frequency hopping bandwidth at 2.4 GHz.
6. The digital modulation amendment to the 2.4 GHz rules.

The goal of this paper is not to chronicle the history of the unlicensed band regulations in significant detail and completeness, but rather to analyze the effects that the authors of this paper – long time WLAN industry veterans – have observed as the result of these major decisions. Some thoughts on future evolutions of the relationship between the rules and WLAN industry are also presented at the end.

## 2. The original rules

### 2.1 FCC Docket No. 81-413

The starting-point for the unlicensed band operation of any device that might meet the current day concept of a WLAN was a “notice of inquiry” (NOI) formally issued on June 30, 1981. The authors have no first hand knowledge of the impetus for this original NOI nor the specific goals of the FCC beyond that which can be read by anyone in the published text of the NOI and the subsequent “Further notice of inquiry and notice of proposed rulemaking” that issued from the FCC on May 26, 1984.

However, from these documents it is clear that the FCC had a vision, even if perhaps not thoroughly understood or supported by industry, that the extensive development work done to that date by the US military on spread spectrum communications could enable new commercial wireless communications products and services if only there were appropriate spectrum bandwidth and rules to let industry innovate in. For this alone, the authors of this paper can easily speak for the entire WLAN industry in saying that those at the FCC involved in making this happen deserve the highest commendation. At a minimum, they have the gratitude and respect of the entire WLAN industry.

### 2.2 FCC First Report and Order on 81-413

On May 24, 1985, the FCC released the “First Report and Order” (FRO) in the matter of “authorization of spread spectrum and other wideband emissions not presently provided for in the FCC Rules and Regulations”. This was the formal starting gun for the WLAN industry, not that much if any of the existing WLAN industry was waiting on the starting line.

The FRO has many notable pieces of information in it relevant to the history of WLANs, not the least of which is the actual original set of rules governing unlicensed access to the 902-928 MHz, 2,400-2,483.5 MHz and 5,725-5,875 MHz industrial, scientific and medical (ISM) bands. For example, the FRO added definitions to Part 2 of the FCC rules for key terms such as “spread spectrum systems”, “direct sequence systems” and “frequency hopping systems” – definitions which remain technically appropriate and unmodified in Part 2 to this very day. For example, “spread spectrum system” is defined as:

An information bearing communications system in which: (1) information is conveyed by modulation of a carrier by some conventional means, (2) the bandwidth is deliberately widened by means of a spreading function over that which would be needed to transmit the information alone (in some spread spectrum systems, a portion of the information being conveyed by the system may be contained in the spreading function).

The actual rules outlined by the FRO as “New Section 15.126” (this later became 15.247) are remarkably simple. Basically they permit operation by “spread spectrum systems” (hence, the importance of the definition above) in the three ISM bands at 900, 2,400, and 5,800 MHz subject only to the restrictions of:

1. 1 Watt maximum peak output power.
2. 20 dB sideband suppression outside the operating channel.
3. Must accept any interference from other ISM band devices.
4. Frequency hopping (FH) devices must have at least 75 non-overlapping hops of no more than 25 kHz channel bandwidth.
5. Direct sequence (DS) devices must have at least a 500 kHz wide 6 dB bandwidth.

The most astonishing observation of these original rules as viewed by those familiar with today's 15.247 ISM rules is just how simple the original rules were. For example, there's no discussion about antenna gain or processing gain for DS. Point (3) above on accepting any interference is there and was actually a point of concern raised by incumbent ISM band users in the in response to the NOI. This is a point that has frequently been “forgotten” by many members of the WLAN industry over the years both in regards to other Part 15 devices

and more importantly in regards to actual “industrial”, “scientific” and/or “medical” devices in this “ISM” band.

### 2.3 Early WLAN products

The reaction to the FCC’s monumental allowance of unlicensed spread spectrum systems in 1985 was not an immediate flood of equipment authorization applications. By today’s standards, it was not even a trickle. Figure 1 shows applications per year over the history of unlicensed ISM rules and the early years are effectively zero.

About the first product to be certified that even remotely resembled a WLAN was the Telesystems “ARLAN-SST” (circa 1988) as illustrated in Figure 2. This device was huge by today’s standards – it probably could not fit in most shoeboxes. Telesystems, a company based in Canada, was later bought by Telxon, then spun out as Aironet, and then bought again by Cisco Systems which is today the world’s largest supplier of WLAN equipment. Evidently it does pay to be first sometimes, though it helps to have patience too.

**Figure 1** Unlicensed band equipment authorizations

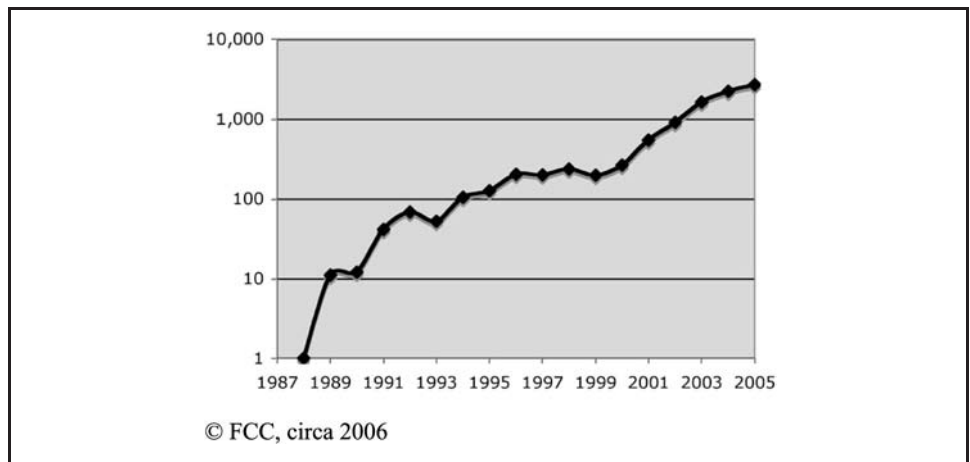

**Figure 2** The Telesystems ARLAN-SST, circa 1988

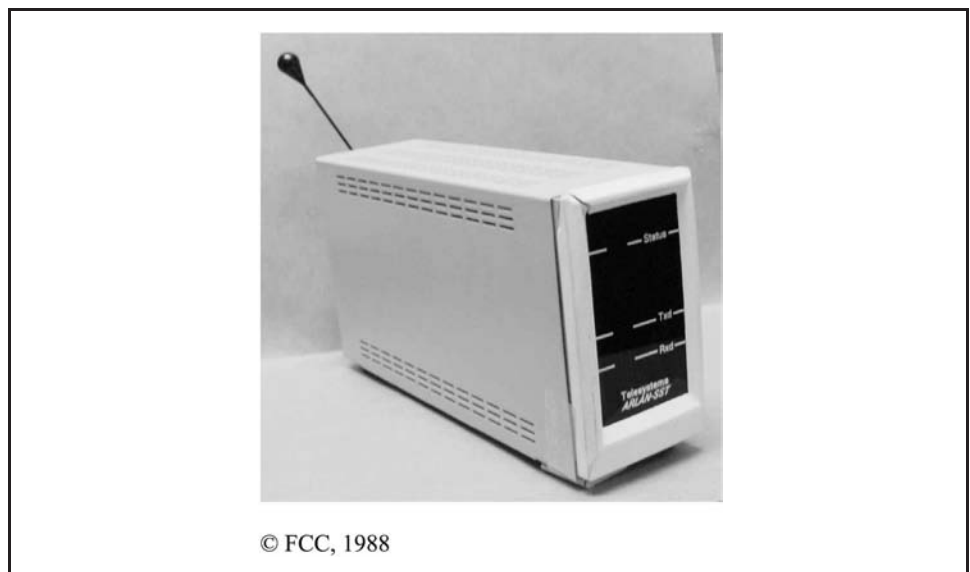

Another very early “WLAN” product from about 1989 was the Proxim 900 MHz “RangeLAN” product. It had an RS-232 interface, used direct-sequence modulation, and operated up to 220 kb/s. Like the Telesystems ARLAN, it was not used to do a lot of Internet surfing. While PC manufacturers of the time considered these as network interface devices, the main sales of these types of products were to specialty terminal manufacturers in mobile logistics applications such as warehouse or retail inventory tracking. There were no “access points” as that term is used today – just “peer to peer” operation. And of course, there were absolutely no multi-company industry standards.

### 3. The early revisions to the rules

#### 3.1 FCC Docket No. 89-354

With this revision issued in a July 1990 Report and Order the FCC added the controversial limitation that direct sequence systems must have at least 10 dB of processing gain as measured by the receiving device by examining the demodulated output with and without the spreading function applied. For many systems, this was nearly impossible to test and the WLAN industry soon complained bitterly. It could have been much worse – the original docket suggested a minimum processing gain of 127 chips, or about 21 dB. For the original 802.11 direct sequence system, this would have limited operation in the QPSK mode to about 500 kb/s even if the entire 2.4 GHz band were occupied as a single channel instead of the three non-overlapping channels that were specified at 2 Mb/s. The FCC also expanded the frequency hopping channel bandwidth for the 2.4 GHz and 5.8 GHz bands to 1 MHz maximum. And this docket added the first of many rules governing the use of directional antennas.

Although not part of Docket No. 89-354, the FCC soon added the “CW jamming margin test” to the 15.247 rules. The CW jamming margin test allowed equipment manufacturers to certify the processing gain of direct sequence receivers solely with measurements that could be made external to the product. The theoretical basis for the CW jamming margin test is quite sound – assuming that the actual device under test is indeed a direct sequence spread spectrum receiver. The tendency of WLAN industry parties that had proprietary technology agendas to ignore that last fact is what caused much of the later controversy surrounding the use of this test.

#### 3.2 Early 2.4 GHz products

As is evident from Figure 1, by 1994 there were about 100 products per year being certified in the ISM bands. However, most of these were not WLANs as that term is understood today. Cordless phones, sensor devices, remote controls and outdoor point-to-point links were all experimenting with products in these bands. In 1994, Proxim introduced the RangeLAN2 product family illustrated in Figure 3. These were 1.6 Mb/s frequency hopping devices at 2.4 GHz. RangeLAN2 included a dedicated access point with Ethernet interface to a wired LAN to enable power savings and roaming for the WLAN clients. A major plus of RangeLAN2 was the PC Card form factor that fit into any standard laptop computer of the day with self-power and no external hardware (other than the antenna). The access points sold for about \$1,500 and the client adapters for about \$500 – outrageous by today’s standards but cheap enough at the time to get sold in the hundred’s of thousands volume for schools/universities, hospitals, stock exchanges, warehouses and other “campus” environments where mobility was highly valued.

In 1991 NCR (later AT&T and Lucent) also sold 1 and 2 Mb/s direct sequence WLANs under the WaveLAN brand. Symbol and Telxon (successor to Telesystems, but later spun out as Aironet) also had WLAN product families with similar performance capabilities but most of their sales were internal to their respective organizations that were leaders in bar code and logistics systems for industrial, government and retailing applications.

**Figure 3** The Proxim RangeLAN2 product family, circa 1994



### 3.3 IEEE 802.11 early days

Against this background of “stable” direct sequence and frequency hopping rules, the IEEE 802.11 standards process was also developing its first standard in this timeframe. 802.11 formally started in 1990 after receiving approval from IEEE 802 ExCOM, but took until about 1994 to converge on the main parameters in the MAC and PHY layers of its standard. As a “working group” within the larger IEEE 802 networking standards body, 802.11 was focused primarily on developing a wireless version of the then successful 802.3 (Ethernet) wired networking standard being deployed in high volume across enterprise and campus environments. But the working group experienced internally the same frequency hopping versus direct sequence “battle” that was happening in the marketplace for the proprietary products of that day. As a result, 802.11 ended up with not one but three PHY layer specifications – one for frequency hopping, one for direct sequence, and one for infrared. These three PHYs were not only incapable of interoperating with each other but also the direct sequence and frequency hopping PHYs both at 2.4 GHz caused significant mutual interference if co-located. Both the direct sequence and the frequency hopping PHYs supported 1 Mb/s and 2 Mb/s data rates.

It took until 1997 to get the original 802.11 standard formally adopted by the IEEE. By that time, proprietary products were commercially successful and available at comparable or lower costs and comparable or higher performance. Unsurprisingly, initial 802.11 products, whether in the direct sequence or frequency hopping variant, did not make much impact on the WLAN market.

### 3.4 Wireless LAN interoperability forum

As the 802.11 process dragged on for years and was failing to produce a single unified standard, Proxim and its OEM customers were steadily building an ever-increasing family of interoperable products from many different vendors (though all based at core on Proxim’s silicon). In response to the desire of these vendors to be able to “certify” interoperability of their products, the Wireless LAN Interoperability Forum (WLIF) was formed around 1996 by Proxim, Motorola, IBM, HP, Intermec and eventually about 20 other companies.

WLIF adopted Proxim’s 2.4 GHz frequency hopping technology as the “OpenAir” standard. And WLIF created interoperability compliance testing standards to ensure that OpenAir products would seamlessly interoperate with each other – a key consideration

conspicuously lacking with early 802.11 products from different vendors. At its peak, WLIF had about 40 certified products that were sold by about 150 different vendors (not all WLIF members).

### 3.5 HomeRF early days

Further in response to the frustratingly slow and balkanized 802.11 process, HomeRF was formed in late 1996 by Intel, Microsoft, HP, Compaq, and IBM. Initially the goal for HomeRF was a WLAN for the home that would emphasize low-cost, ease of use, using the home PC as an information “hub”, and integration of the WLAN with toll-quality voice cordless phone capability. It was not long though before HomeRF became basically a technology for sharing broadband Internet service in the home without the hassle of wiring but with the convenience of mobility.

The initial plan for HomeRF as proposed by HP was to base the PHY layer on the 802.11 frequency hopping standard but to relax various performance parameters such that low cost components then used by DECT cordless phones (and Proxim’s RangeLAN2 products) could be leveraged for lower cost. The MAC layer proposal was a hybrid of 802.11 with DECT so that both toll-quality cordless voice as well as data networking would be available. HomeRF also added support for priority “streaming” or “quality of service” – a subject that 802.11e would also address many years later. This hybrid MAC approach of HomeRF is illustrated in Figure 4. However, HomeRF had to face the same reality that would drive the entire WLAN industry soon – it is all about the silicon, or more specifically about having a highly integrated and efficient baseband/MAC chip.

In 1998, HomeRF solved this problem by effectively merging with WLIF when it switched to a variant of the OpenAir PHY that would be compatible with Proxim’s custom silicon. Almost immediately, HomeRF leapfrogged 802.11 in sales volume and became the leader in the fastest growing segment of the WLAN business – the home. With a “two-chip” solution as shown in Figure 5, HomeRF could easily meet the magic sub-\$100 price points and even form factors as small as Compact Flash adapters. And since every HomeRF product had Proxim silicon within it, the products were also capable of roaming onto OpenAir networks that provided similar capabilities to 802.11 and were at the time much more prevalent in the market. At this point HomeRF had nearly 100 member companies involved with it. HomeRF had become an existential threat to 802.11.

**Figure 4** Hybrid MAC processing in HomeRF

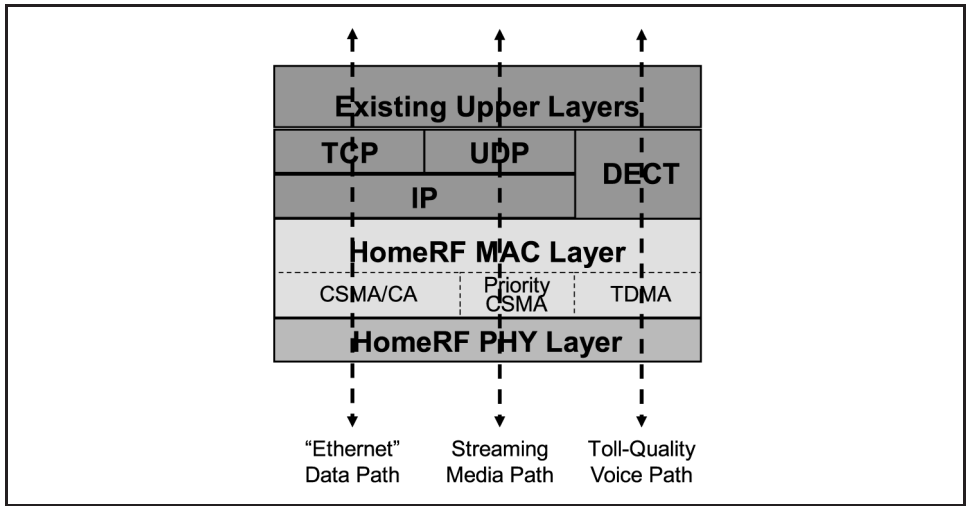

**Figure 5** HomeRF “two-chip” adaptor, circa 1998

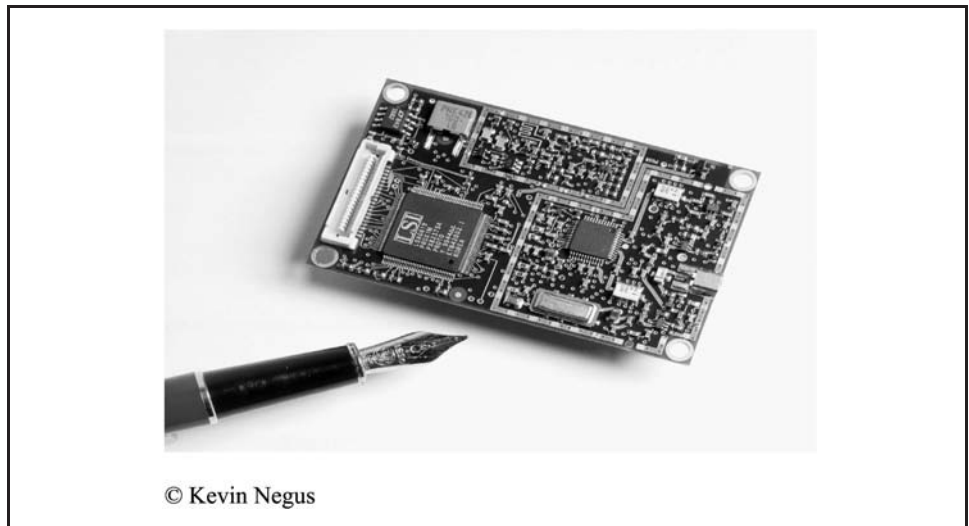

#### 4. The U-NII process

##### 4.1 Background and motivation

By about 1994 the “common wisdom” in the WLAN industry was that the 900 MHz ISM band was far too crowded to deploy any products and even the 2.4 GHz band suffered significant interference from both Part 15 devices and microwave ovens. This of course seems laughable today after about 1 billion 2.4 GHz ISM devices (and probably 1 billion microwave ovens) have been deployed and the band is still going strong. But it is always tough to argue for additional spectrum if you cannot point to running out of existing spectrum.

However, the sounder technical argument (at the time) for opening up spectrum at 5 GHz for WLANs was the perceived need for much higher data rates and the perceived belief that such data rates could not be achieved under the ISM band regulations and crowding conditions.

Furthermore, by the mid-1990s there was considerable angst surrounding the success of GSM and DCS as digital cellular phone systems that were top-down mandated by regulators in Europe versus the relatively sparse deployments of the competing digital cellular telephone systems in the USA where regulators were applying a relatively lighter hand. In 1996, the HIPERLAN standard completed development in Europe for WLAN operation at about 23.5 Mb/s in dedicated spectrum at 5.15-5.30 GHz. Since US WLAN products were only doing 1 or 2 Mb/s in the “crowded and unregulated” ISM bands, there was a palpable fear that “once again” those brilliant European central planning regulators would succeed while “unregulated” competition in the USA would fail.

##### 4.2 ET Docket No. 96-102

In January 1997, the FCC issued a Report and Order that created the Unlicensed National Information Infrastructure (U-NII) rules for 5 GHz operation. Rather than modify the existing 15.247 rules for unlicensed operation in the ISM bands, this created an entirely new set of rules under 15.401-407. The specific band allocations were 5.15-5.35 GHz and 5.725-5.825 GHz (the latter band already allocated to unlicensed use under 15.247). The FCC wisely chose a set of rules that would enable HIPERLAN but not mandate it.

But more importantly, the FCC took a very different approach to unlicensed band regulation than that then in place under 15.247 rules. Basically, the U-NII rules restricted a system only to a maximum total power and a maximum power density. For a system to reach the maximum power, which was different in each 100 MHz segment, a 20 MHz channel

bandwidth (or spectral occupancy) was required. Thus, the FCC was able to highly influence manufacturers to build high data rate wideband systems that would be very different from the 1-2Mb/s products of the ISM bands without actually mandating any specific PHY characteristics such as spread spectrum.

#### 4.3 IEEE 802.11a

In early 1997, the High Speed Study Group was formed within the 802.11 Working Group. In March 1997, this Study Group recommended the formation of two project authorizations each of which would eventually lead to a distinct Task Group.

One proposal was to develop a “Standard for Wireless Medium Access Method (MAC) and Physical Layer (PHY) Specifications – Supplement for High Speed Physical Layer (PHY) in the 5 GHz band”. After some refinement by the Study Group, the IEEE 802 approved the formation of a Task Group (known as TGa) to develop this PHY layer standard (to be called 802.11a) in mid-1997. The other proposal led to the formation of TGb to develop a higher speed 2.4 GHz PHY layer that would eventually be known as 802.11b – more on this later.

The 802.11a committee’s specific goals were to develop an amendment to 802.11 so that operation with a PHY data rate of 20Mb/s or greater would be possible under the 5 GHz U-NII rules. There were some in the WLAN industry of that time who felt that TGa should simply embrace HIPERLAN and be done – one global standard for WLAN (assuming that Japan and other countries would also adopt it). But this was never a serious possibility because the HIPERLAN MAC layer was very different from that of 802.11 and TGa had no authority to change the MAC layer.

By January 1998, six companies had indicated their intentions to present and had previewed proposals to meet or exceed the minimum requirements of TGa. Two of these proposals were based upon Orthogonal Frequency Division Multiplexing (OFDM), two were based upon single-carrier modulation schemes, one was based upon Bi-Orthogonal Keying (BOK) direct sequence spread spectrum, and the final one was based upon Pulse Position Modulation (PPM). By March of 1998 as the formal proposal process was unfolding, these six initial proposals collapsed to three final proposals as the BOK proposal was withdrawn, the two OFDM proposals were merged into one, and the two single-carrier proposals were also merged into one.

The down selection process began in May of 1998. First, the PPM proposal dropped from the ballot due to lack of support. On the second ballot, the OFDM proposal prevailed over the single-carrier proposal with a 54 percent approval. However, it took until July of 1998 for the OFDM proposal to reach the required 75 percent threshold at which it became the sole basis for the proposed standard. Formal adoption of 802.11a as an IEEE standard was completed in September of 1999. The adopted standard uses 52 discrete subcarriers (four of which are pilots) as shown in Figure 6. With convolutional encoding, intra-symbol interleaving, BPSK through 64-QAM subcarrier modulation mapping and four us symbol time, 802.11a provides up to 54 Mb/s PHY data rates with excellent performance for most indoor WLAN applications.

**Figure 6** OFDM subcarriers for IEEE 802.11a

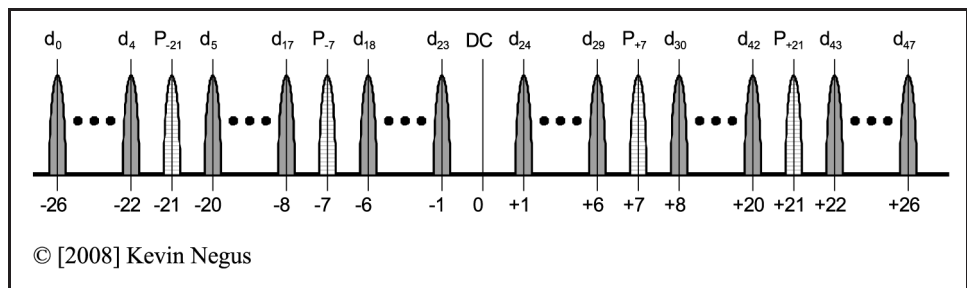

The 802.11a selection process truly validated the wisdom of the FCC's approach to the U-NII regulations. Multiple competing technology approaches were considered on their own merits for the specific WLAN application without undue worry about regulatory compliance. Although spread-spectrum technology was considered, the winning proposal, OFDM, was not a spread spectrum system at all. Where spread spectrum systems widen the occupied bandwidth with a spreading function, OFDM instead does not widen the bandwidth at all. In fact, for the high data rate applications of interest to WLAN it can be readily argued that OFDM somewhat "narrows" the bandwidth in the sense that the inevitable sidebands created by the modulating (and spreading if applicable) process are much less than a single carrier or spread spectrum system as seen graphically in Figure 7.

Despite the technical superiority of 802.11a over either 802.11b or HomeRF and the attraction of the unoccupied additional U-NII spectrum, it was not until September of 2001 that products compliant with 802.11a became commercially available (from Proxim, ironically). The reason for the delay was silicon availability especially given the low cost and high performance points being set in the marketplace by 802.11b and HomeRF. A start-up company, Atheros, was the first to make such silicon commercially available on a widespread basis.

#### 4.4 Observations on the U-NII experience

As of this date, the U-NII process has had a profound effect upon the WLAN industry but not by extensive product shipments and usage of the allocated bands by WLANs. The authors believe the U-NII process has affected the WLAN industry and more broadly the whole wireless communications industry as discussed below.

First, the U-NII timing with the start of 802.11a gave an opportunity for OFDM to be considered fairly in comparison to other approaches for high-speed wireless data transmission and it was found to be superior. This result has repeated itself several times since such as the selection of OFDM for 802.11g at 2.4 GHz (once the rules were changed), for ultra-wideband (WiMedia), for outdoor broadband networking (WiMax), and more recently for fourth generation cellular networks (LTE).

Second, the U-NII process later led to cooperation between primary (licensed) users of a band and secondary unlicensed users over a sharing etiquette. This happened in 2002 and 2003 when WLAN industry representatives met with government radar representatives to establish a procedure for detecting and avoiding interference with radars not only in the then-existing U-NII bands but also in the additional 5,470-5,725 MHz band. The established etiquette includes the use of transmit power control to minimize interference to other users and dynamic frequency selection to ensure that secondary users defer to primary users. This ought to be a model for maximizing spectrum value via shared usage between primary licensed users and secondary unlicensed users especially given the technology potential of wireless communications systems based on spatial processing.

**Figure 7** OFDM channelization for IEEE 802.11a

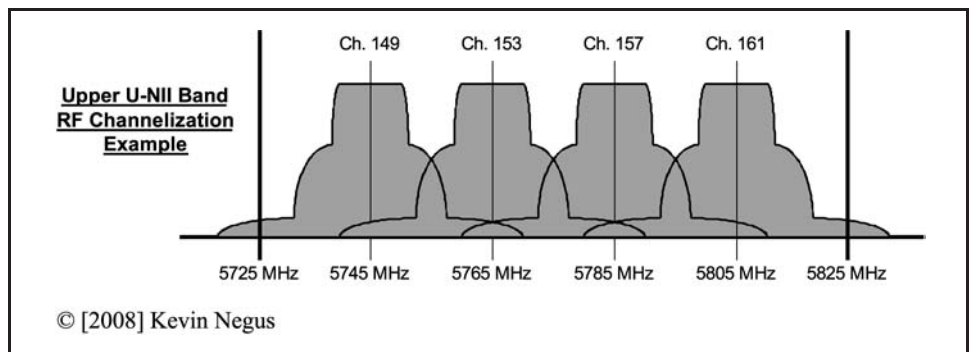

Third, the over 500 MHz of available spectrum under U-NII is clearly the future of the WLAN industry despite the resilience of continued use of the smaller and more crowded 2.4 GHz band. The U-NII spectrum as utilized by 802.11n networks is critical for the WLAN industry's vision of an always-connected mobile multi-media delivery system that covers all indoor and public congregation spaces.

## 5. High rate direct sequence

### 5.1 IEEE 802.11b background and beginnings

As mentioned above, in 1997 the IEEE 802.11 Working Group authorized the formation of Task Group B (TGb) to develop a high data rate PHY layer amendment to the initial 802.11 standard. TGb's goals were fundamentally to achieve at least 10 Mb/s data rate in the 2.4 GHz ISM band with backwards compatibility or interoperability to at least one of the then-existing 802.11 PHYs.

In 1997, "conventional wisdom" in the WLAN industry was that for practical systems, about 4 Mb/s was the upper limit for either direct sequence or frequency hopping spread spectrum devices under the then-existing FCC 15.247 ISM band rules at 2.4 GHz. This seemed to be anecdotally validated by both the original 802.11 PHYs and the proprietary products commercially available at the time.

It was extremely difficult to get beyond about 4 Mb/s using frequency hopping so long as the FCC imposed a hard limit of 1 MHz channel bandwidth. And even achieving 4 Mb/s would require considerable additional complexity and expense compared to the 1 and 2 Mb/s frequency hopping WLANs of the day. A pioneering WLAN company, Symbol Technology, had approached the FCC years before the 802.11b process had begun and asked to have the maximum frequency hopping channel bandwidth increased to 5 MHz which would have enabled 10 Mb/s data rates for frequency hopping WLANs at moderate expense and complexity. But the FCC denied that request and thus frequency hopping was never a serious candidate for TGb.

For direct sequence WLANs to that date, the deployment of access points in a 2-dimensional layout meant that for a "7-cell" pattern the minimum number of frequency channels was 3 if a single spreading code was used at each frequency. This meant for the 2.4 GHz band that each direct sequence channel needed to be no more than about 20 MHz after spreading. Since a processing gain of 10 dB (or a spreading factor of 10) was required, then the "un-spread" bandwidth had to be about 2 MHz or less. And since it was impractical to use modulation techniques other than PSK for direct sequence systems, this in turn limited the conventional direct sequence WLAN to about the same 4 Mb/s ceiling as with frequency hopping.

But as the parties involved with TGb knew, there was another way to achieve higher data rates using direct sequence by exploiting the additional signaling dimension anticipated by the FCC in its original definition of spread spectrum as quoted in section II-B herein – "a portion of the information being conveyed by the system may be contained in the spreading function".

Several companies or organizations made proposals to TGb for a 10 Mb/s class PHY but when the formal voting started in March of 1998, there were two proposals, one from tiny start-up Micrilor and one from WLAN chip industry leader Harris Semiconductor, which had enough support and merit to be serious contenders for the eventual 802.11b standard. Both proposals were based upon "M-ary Bi-Orthogonal Keying" (MBOK) in some form and utilized code set selection of orthogonal spreading sequences in combination with conventional PSK modulation. There were multiple minor variations between the two proposals but it was one particular significant difference that generated the meaningful performance differences and most of the controversy. The Micrilor proposal was based upon spreading sequences of length 16 chips while the Harris proposal used sequences only of length 8 chips.

Micrilor's system has some significant technical advantages. First, note that 16 chips versus 8 chips is not "twice as many" in the code domain – it is the difference between 65,536 theoretical code choices on either the real or imaginary axis versus 256 choices. Thus, Micrilor could choose codes (via computer search) with excellent multipath performance and use different codes in adjacent access point cells on the same frequency channel. Micrilor's system also, like many military direct sequence systems, featured "TRANSEC" or transmission layer security where codes were changed as part of the data encryption process. Such systems are virtually impossible to hack into by listening over the air.

But Harris' system had some advantages too especially in terms of backwards compatibility with the original 802.11 direct sequence PHY. Unlike Micrilor, Harris' proposal supported three non-overlapping channels in the 2.4 GHz band and such channels could be coincident with those of the original direct sequence PHY such that real time mixed mode operation was straightforward. Also with three channels instead of two in Micrilor's proposal, the Harris system had more frequency agility to avoid interference such as a microwave oven in the ISM band. And the Harris system went 11 Mb/s instead of 10 Mb/s for Micrilor.

However in 1998, there was an accepted orthodoxy in the WLAN industry that the 10 dB processing gain requirement of the FCC 15.247 rules meant the spreading sequences had to be ten chips in length or greater. The most common sequence in use from the original 900 MHz Proxim RangeLAN on through the 802.11 direct sequence PHY was the 11-chip Barker code. How, asked the WLAN community of Harris Semiconductor, was this 8-chip proposal ever going to be certifiable under 15.247 rules?

### *5.2 Harris Semiconductor convinces the FCC to accept 8-chip MBOK*

In 1997, Harris Semiconductor's approached the FCC with a description of their MBOK proposal. Harris submitted detailed mathematical analysis on how MBOK meets the 10 dB processing gain requirement along with measured results of the CW Jamming Margin tests from an independent test laboratory. Harris was able to prove that MBOK meets the 10dB processing gain requirement by summing processing gain from channel spreading and coding gain from the 8-chip Walsh codes. The FCC still debated the argument and industry support for such technology. The FCC decided not to allow MBOK until a commercial product was available for certification using the Harris MBOK chipset. Later in 1997 an independent set of FCC Part 15.247 tests were conduct on a PCMCIA 802.11 adaptor from Aironet (later acquired by Cisco System) and submitted for FCC approval. Aironet received FCC Part 15.247 approval on a PCMCIA adaptor based on Harris' MBOK technology. Following Aironet's FCC approval, MBOK was allowed under FCC Part 15.247 rules.

### *5.3 Completion of the IEEE 802.11b process*

Despite Harris' success in getting the FCC to agree that 8-chip MBOK was certifiable, Harris was never able to get >50 percent of the 802.11 voting members to approve its MBOK proposal. But neither did Micrilor, though at one point Micrilor did get to precisely 50 percent. However, in July 1998 a "compromise" proposal was put forward which easily received > 75 percent approval by offering the excellent multipath performance of Micrilor with the backwards-compatible 3-channel advantages of Harris at 11 Mb/s. This proposal was called "Complementary Code Keying" (CCK). A proposed implementation block diagram for a CCK modulator as presented to TGb is shown in Figure 8. In CCK the codes are selected from a code set derived from a complementary code.

Formal adoption of IEEE 802.11b was completed in September 1999. First commercial products appeared at about that same time. The "Wireless Ethernet Compatibility Alliance" (WECA) was formed about this timeframe and provided a multi-vendor interoperability certification mechanism for 802.11b products. WECA also promoted the trademark "Wi-Fi" (known as Wireless Fidelity) and eventually renamed the organization as the Wi-Fi Alliance. Harris' PRISM chipset as shown in Figure 9 was a key enabler of the early 802.11b products.

**Figure 8** 802.11b Modulator block diagram

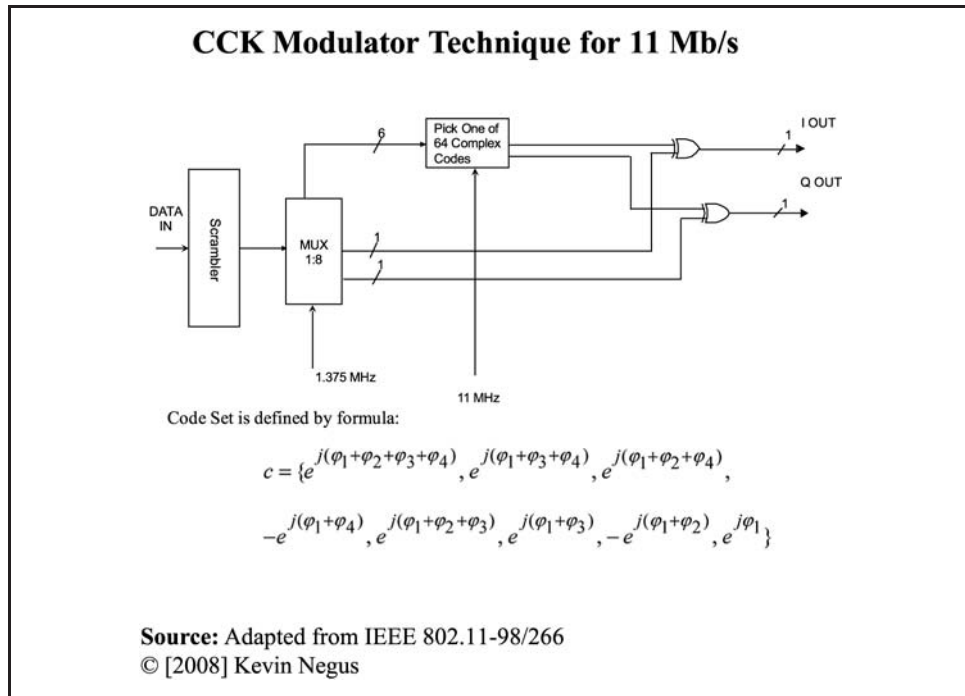

**Figure 9** Harris PRISM 802.11b Chipset, circa 1998

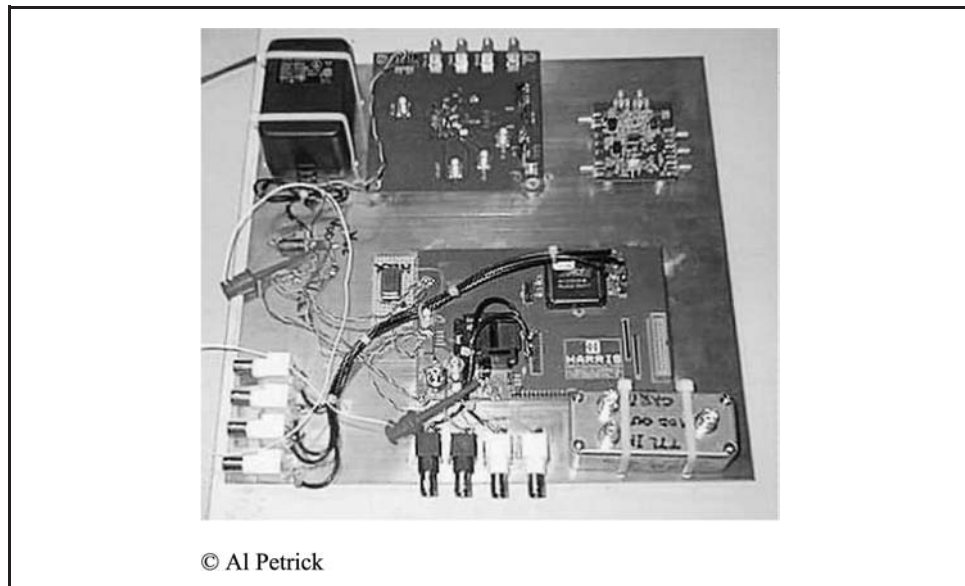

With five chips versus the two for HomeRF, the initial products were priced well above those of HomeRF and were sold mostly to performance driven enterprise applications. But during 2000 the price gap between the two technologies narrowed considerably and 802.11b products achieved widespread adoption including the consumer market. By 2001, the price differences were insignificant as 2-chip 802.11b products were introduced. Because the competitive 10Mb/s HomeRF products did not become commercially available until mid-2001, by the end of 2001 802.11b products took over the entire WLAN market.

#### *5.4 Observations on the 802.11b direct sequence certification*

To this day there remain people within the WLAN industry who question whether or not the certification of 802.11b was ever “correct” under the FCC 15.247 direct sequence rules. The authors would like to put forth the following “facts” that will help the reader come to their own conclusions:

- 802.11b is definitely a direct sequence spread spectrum technology, albeit one with spreading sequences of very limited length. But it is hard to see how having 11 chips instead of 8 chips can be the real determinant of being a “true” direct sequence system versus an imposter. If military or cellular systems were the model for direct sequence bona fides then anything less than 100-1000 chips would not be a “true” direct sequence system.
- The CW jamming margin test has a sound technology basis for determining direct sequence processing gain – assuming of course that the device under test actually is a direct sequence system. Many people argue what is the point of this test since everything about the device is “known” from the standard it complies with. This is true but misses the point. The FCC certifies equipment not standards. People also argue that the CW jamming margin test is deficient because systems that are clearly not direct sequence, or even spread spectrum, such as coded OFDM or highly coded single carrier have been shown to “pass” the CW jamming margin test. But this is an honesty deficiency on the part of those applying the test to such systems, not a proper criticism of the test for its intended purpose.
- The FCC required (as of 1998 at least) that direct sequence systems have at least 10 dB of processing gain. 802.11b did not have 10 dB of processing gain. It had 9 dB of processing gain. 802.11b products could pass the CW jamming margin test to show > 10 dB processing gain partially due to the inaccuracies of the test and partially due to a small amount of coding gain in the CCK process relative to a narrow band interference source.

## **6. Wideband frequency hopping**

### *6.1 HomeRF petition for wideband frequency hopping*

In 1998 it was clear to the members of the HomeRF Working Group (HRFWG) that the 802.11b standard by one way or another would be enabling products in the marketplace within a year or two that would operate at 10 Mb/s in the 2.4 GHz band. Thus HomeRF would not be a viable technology long term unless it could offer a similar performance roadmap in a similar timeframe.

After multiple informal discussions, the HRFWG formally petitioned the FCC in November of 1998 and asked for permission to operate in the 2.4GHz ISM band with 75 hopping channels as required in the existing rules but with the 1MHz channel bandwidth limitation relaxed to 5 MHz. HomeRF argued that such a system would still appear equally “random” or “spread” to other users of the band. However, the FCC did not believe that such a flagrant violation of the 1MHz requirement was possible without rulemaking. The FCC instead committed itself to conducting a “rocket-docket” rulemaking procedure based on the HomeRF proposal.

### *6.2 ET Docket No. 99-231*

On June 24, 1999, the FCC issued the Notice of Proposed Rulemaking (NPRM) for ET Docket No. 99-231. The FCC adopted the HomeRF proposal in its entirety and also took the opportunity to address issues that had arisen concerning the CW jamming margin test for direct sequence devices with less than ten chips per symbol. A total debacle, at least by WLAN industry standards, promptly commenced.

Unsurprisingly, the many members of the HRFWG, WLIF and various Proxim business partners sent encouraging letters of support praising the FCC for the NPRM and urging

rapid adoption. But just about every organization with a vested interest in the success of 802.11b wrote a letter of protest claiming that calamitous interference was imminent, consumers would be swindled by poor performing HomeRF devices, and WLAN standards harmonization would be impossible. It is amazing in retrospect that they did not predict airplanes flying into buildings. No FCC commissioner went unvisited during this process and no congressional member with FCC oversight authority went un-lobbied.

In the end, a live debate was held in front of the last FCC commissioner to decide on the matter. Along the way the proposal was modified to 15 non-overlapping channels (that is, the same as Symbol, who now objected, had originally proposed years earlier) and 125 mW of maximum transmit power. On September 25, 2000 the “rocket-docket” was completed and the new rules for wideband frequency hopping were formally adopted. HomeRF had “succeeded” in getting the 2.4GHz ISM band rules changed to enable its second generation 10 Mb/s devices with backwards compatibility. But 802.11b and WECA were the ones who really “succeeded” because they had managed to delay HomeRF at this critical juncture and peel off many supporting members with the fear that uncertainty inevitably brings.

### 6.3 HomeRF 2.0

With the rules change in hand, HomeRF moved quickly to complete the revision 2.0 specification in late 2000. The group specified a channel access methodology based on 5 MHz “superchannels” as shown in Figure 10 so that the 1 MHz channels would still be supported for backwards compatibility and maximum range (especially for voice connections). Proxim completed the HomeRF 2.0 custom chip development as fast as possible and with first pass success had working 10 Mb/s samples by the spring of 2001. But the HRFWG was by then imploding due to the competitive pressures of success in the marketplace by 802.11b. By the summer of 2001 when the first HomeRF 2.0 products were ready for market, the HRFWG collapsed internally. By the end of 2001, HomeRF was finished. The WLAN industry had one standard – Wi-Fi.

### 6.4 What If . . .

A reasonable question to ponder now several years later is “what if the FCC had merely given HomeRF a waiver as they did for 802.11b” – then what would have happened? The authors offer the following scenarios in order of likelihood:

- Wi-Fi would have won anyways. HomeRF was far from being a standard usable in enterprise networking while 802.11b was an acceptable, if not ideal, standard for home networking. And 802.11b simply had much more silicon development behind it than Proxim alone even in the early timeframes before the wideband frequency hopping rulemaking complicated everything. While HomeRF 2.0 would have likely shipped in

**Figure 10** HomeRF 2.0 channelization

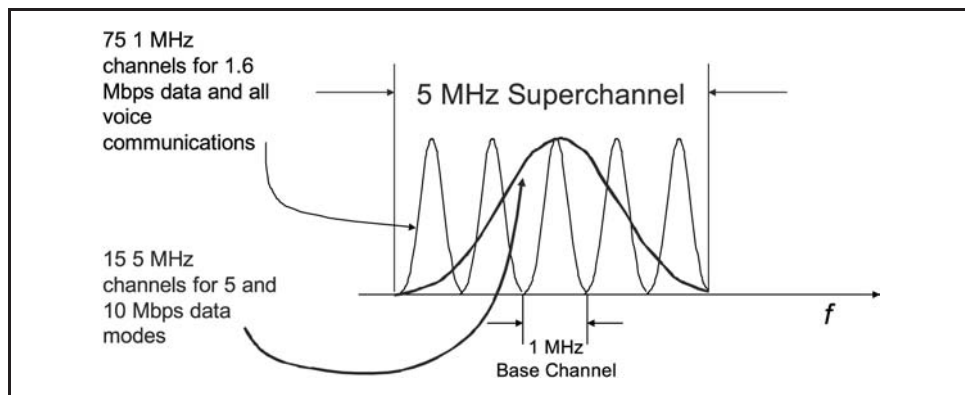

considerable quantities, the voice and data combination for the home was ahead of its time and eventually the aggressive silicon roadmap of multiple 802.11b competitors would have overwhelmed Proxim and HomeRF.

- While the above is the more likely outcome, it would by no means have been certain. If the FCC had waived on wideband frequency hopping in 1998, more HomeRF silicon providers could have come on board quickly – for example, all of the major DECT silicon providers were very close to committing. Thus a distinct second scenario of credible likelihood is that Wi-Fi and HomeRF would have eventually merged – probably under the process that produced 802.11g. In this scenario, the HomeRF PHY would have become an 802.11 standard, the HomeRF MAC would have been folded into 802.11e, the 802.11g PHY would have supported backwards compatibility to both 802.11b and HomeRF 2.0, WECA (Wi-Fi Alliance) would have merged with WLIF and focused on enterprise networks, and HomeRF would have become a consumer WLAN marketing effort only.
- Although it seems outrageous now, there was a finite possibility that HomeRF could have won everything. For this scenario to have happened, the FCC would have waived the wideband rules in 1998, Proxim and its partners would have executed “flawlessly” (as opposed to just the “very well” that they did), and the multiple 802.11b silicon providers would have all had to have struggled much more in their quest to cost-reduce their chipsets.

Of course, it is equally fair to ask whether any of these scenarios would have really made user experiences any better than what has actually transpired. Probably the best that can be said for any of these scenarios, or for what actually did happen, is that the competition between Wi-Fi and HomeRF made both technologies better than they would have otherwise been. And that has to be good in the long run for everyone.

## 7. Digital modulation

### 7.1 The “Final” revision to the 2.4 GHz rules

After the wideband frequency hopping proceeding was completed, the FCC re-visited the whole issue of spread spectrum as a requirement for the 2.4 GHz band. By this point in time, the rules had become so convoluted that the best way to fix them was basically to start over. The FCC had also been petitioned by a Canadian company, Wi-LAN, to allow OFDM at 2.4 GHz under the direct sequence spread spectrum rules. The FCC correctly denied this petition because OFDM simply is not a spread spectrum system at all per the definition used by the FCC (and commonly understood by the industry at large). Texas Instruments was also publicly claiming that its Packet Binary Convolution Coding (PBCC) technique for extending the data rate of 802.11b was compliant with the direct sequence spread spectrum rules even though no such compliance had actually been certified by the FCC.

However, the FCC was completely open to allowing any system access to this band under a “digital modulation” rule so long as the total conducted power remained below 1 W and the existing direct sequence maximum power spectral density of +8 dBm in 3 kHz was not exceeded. On May 11, 2001, the FCC issued a “Further Notice of Proposed Rulemaking” under the same ET Docket No. 99-231 that had covered the wideband frequency hopping proceeding. This proposal also included dropping the controversial processing gain requirement for direct sequence and hence also the CW jamming margin test. Almost exactly 1 year later on May 30, 2002, the FCC issued a “Second Report and Order” that codified these proposals into the revised 15.247 rules in place today.

Ironically, the new digital modulation rules not only allowed single-carrier and OFDM, that is, non-spread spectrum systems, to be certified. But also, 802.11b CCK and the HomeRF 2.0 waveforms would be permitted at their intended power levels under the digital modulation rules. The authors cannot help but conclude that the interactions between WLAN industry standards and products with the FCC’s 15.247 rules certainly would have been far less

complicated or controversial if only the digital modulation rules had been in the original 1985 ruling.

### **7.2 IEEE 802.11g**

At the March 2000 meeting of the IEEE 802.11 Working Group, a “Higher Rate” Study Group (HRbSG) was formed and authorized “to investigate technical extensions that are interoperable with 802.11b and that can lead to higher than 20Mbps data rates and other performance improvements to the existing 802.11b standard.” By July 2000 the HRbSG formally became the 802.11g Task Group (TGg). The Task Group then followed a process that in principle was similar to that of TGA. First, a set of requirements was determined. Then proposals for the standard were considered. Next the proposals were down-selected to a single consensus proposal. And finally, the consensus proposal was edited into final form and circulated for comments and ultimately approval.

Three proposals received detailed consideration. Texas Instruments (TI) via a recent acquisition of startup Alantro Communications proposed Packet Binary Convolutional Coding (PBCC) with 8PSK modulation to provide 22 Mb/s from a single-carrier system. The proposal was later amended to add a 33 Mb/s mode as well. A small Irish company called Supergold Communications proposed a direct sequence based system called Sequence Coded Modulation (SQM). By using longer spreading codes than 802.11b and higher order modulation (16QAM), SQM supported data rates of 22 and 30 Mb/s depending upon the amount of coding overhead used. Finally, Intersil (formerly Harris Semiconductor) proposed CCK-OFDM using a modified form of OFDM from 802.11a. The modifications included preamble changes to ensure backwards compatibility with 802.11b and symbol rate changes to allow common reference frequencies with 802.11b. With these minor changes, data rates up to 59.4 Mb/s were possible using the same 52-carrier,  $\frac{3}{4}$  rate coding, 64QAM system adopted in 802.11a.

When voting commenced in March of 2001, the only proposal technically “legal” under the then-existing 15.247 rules, the Supergold direct sequence system, was promptly eliminated. TI’s PBCC system, which its supporters claimed was more likely to win FCC approval than Intersil’s CCK-OFDM, was eliminated at the next meeting in May of 2001. But the sole remaining proposal failed repeatedly to reach the >75 percent consensus need to complete the standard at least partially due to the uncertainty surrounding the 15.247 rules and digital modulation. By the November 2001 meeting, the FCC let TGg know that all proposals would likely be certifiable under digital modulation and that TGg should just go ahead and pick a technology on the merits only. Ironically, none of the three original proposals prevailed as simply adopting 802.11a “as is” at 2.4 GHz became the compromise choice that received >75 percent approval.

By the end of 2002, the first 802.11g compliant products were commercially available even though formal adoption of the standard by the IEEE was not until several months later. But this time neither Proxim nor Harris/Intersil were at the forefront of what would go on to be by far the most successful WLAN technology. A new group of WLAN industry leaders emerged with 802.11g including companies such as Atheros, Broadcom, Intel, Marvell and others. Proxim was sold to Western Multiplex in 2002 and the acquirer took on the Proxim name and went on to bankruptcy in 2005 (though the name lives on with another firm to this day). Intersil which had spun out of Harris in 1999 was bought by Globespan in 2002 and then by Conexant in 2003. The entire Harris WLAN development team that pioneered the PRISM chipset family so essential to Wi-Fi’s victory over HomeRF was laid off by Conexant in late 2007 as they exited the WLAN business.

### **7.3 IEEE 802.11n**

In early 2002, yet another “High Throughput Study Group” was formed and in September 2003 this led to the creation of Task Group (TGn) with the charter to develop a next-generation PHY that would support throughputs of over 100 Mb/s in the 2.4 GHz and 5.0 GHz band. TGn followed the same steps as TGg in the standardization process. TGn

developed a set of basic requirements, a channel model and a proposal down selection process. It was decided early on in the process, backwards compatibility with legacy 802.11g was mandatory as result OFDM became the modulation of choice. Multiple input multiple output (MIMO) antenna technology was first introduced to 802.11 early on in the TGN's process by a startup company – Airgo Networks a pioneer of MIMO technology. In 2004 two consortium groups consisting of industry leaders emerged – Wwise (world-wide spectrum efficiency) and TGN Sync (Task Group n Synchronization). Initially Wwise received support from Airgo Networks, Bermai, Broadcom, Conexant, Texas Instruments and ST Microelectronics, while TGN Sync included companies such as Agere, Atheros, Cisco, Infineon, Marvell, Mitsubishi, Nortel, Panasonic, Philips Semiconductors, Samsung, Sanyo, Sony and Toshiba. Later in the process Motorola joined Wwise after its own proposal failed to gain support while Nokia switched to Wwise and Qualcomm joined TGN Sync.

A call for proposals was initiated and in November 2004 TGN received 32 proposals (four complete and 28 partial). The four completed proposals emerged from Wwise, TGN Sync, MITMOT (Mac and mlmo Technologies for More Throughput'), and Qualcomm. MITMOT received 47.4 percent, TGN Sync 73.7 percent, Wwise 64.7 percent and Qualcomm 56.8 percent. None of the four proposals prevailed and failed to gain > 75 percent approval. All of the proposals were based on MIMO antenna technology with Spatial Division Multiplexing (SDM) and Space-Time Block Coding (STBC) as illustrated in Figure 11. Channel bandwidth and frequency band of operation were the underlying key differences between Wwise and TGN Sync. Wwise was based on 20MHz channels in the 2.4GHz band, while TGN Sync mandated 40MHz channels in the 5GHz band. Wwise argued for 20MHz support and conservatively use the 2.4GHz spectrum with legacy 802.11g for VoIP applications while TGN Sync proclaimed to achieve 150Mb/s by widening the channel and 500 Mb/s with four transmitters using MIMO for steaming video applications.

In May 2005 a final attempt at another down selection vote was cast between Wwise, TGN Sync and MITMOT. TGN Sync was the single remaining technical proposal after reaching >50 percent threshold; however the proposal failed to achieve consensus – 75 percent approval. Knowing neither group's proposal had enough support to be a clear-cut winner, a joint proposal team was formed between Wwise and TGN Sync basically combining both proposals. With TGN on fragile standing with industry pent up frustration, Atheros, Broadcom and Marvell chose to breakaway and formed yet another group – Enhanced Wireless Consortium (EWC), which was viewed as means to form a standard more quickly. A number equipment manufacturer's consumer electronics leaders, joined EWC shortly thereafter. EWC worked towards refining a specification that would increase the basic data rates from

**Figure 11** MIMO and spatial division multiplexing

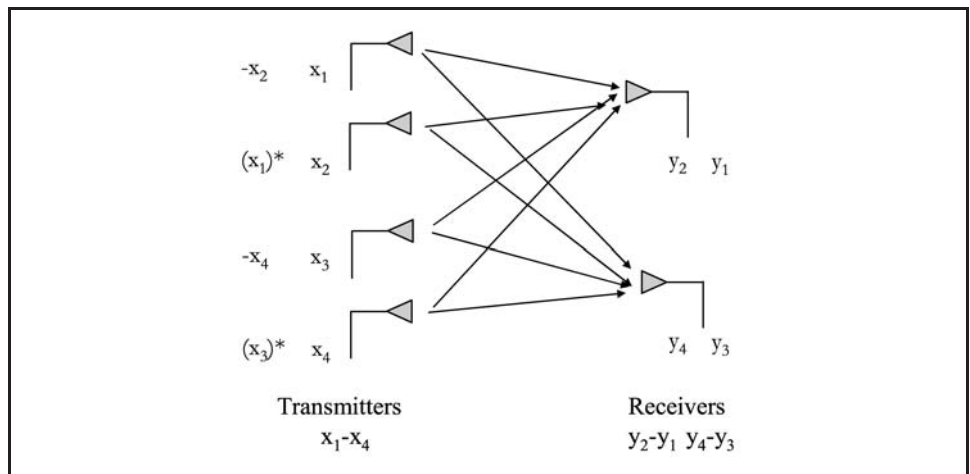

100 Mb/s to 150 Mb/s and achieve speeds up to 600 Mb/s. Later in 2005 EWC worked with the TGn joint proposal team towards a unified technical specification.

In January 2006, the group reached consensus and voted unanimously on the joint proposal that lead to the initial draft standard 802.11n-D1.0. After several rounds of letter ballots and refining a number of technical issues, in March 2007 the group approved the second draft of the standard 802.11n-D2.0 exceeding the 75 percent necessary for approval. Draft 2.0 was based on MIMO antenna technology with Spatial Division Multiplexing and convolutional encoding to achieve data rates up to 600 Mb/s. The draft specifies 20 MHz channels (mandatory) in the 2.4 GHz band to be interoperable with legacy 802.11b and 802.11g devices and 20 MHz and 40 MHz channels to be interoperable with legacy 802.11a in the 5 GHz band. Draft 2.0 allows for any combination of Space Division Multiplexing (configuration of transmitters and receivers) from one transmitter with two receivers (1 × 2) through (4 × 4) in either direction. Another option in the draft shortens the guard band interval from 800 nsec to 400 nsec to further increase the OFDM symbol rate to further increase the data throughput.

In 2005 the first proprietary MIMO technology 802.11 “pre-N” products emerged in the retail market based on chipsets and reference designs from Airgo Networks and Atheros as illustrated in Figure 12. Following the adoption 802.11n draft 1.0 in 2006 Atheros and Broadcom were the first to offer 802.11 “pre-N” reference designs interoperable to draft 1.0. This enabled an immediate uptake in multi-vendor product offerings in the market. Plagued by interoperability and interference issues with legacy 802.11b/g products, the WLAN market struggled with gaining consumer mindshare for pre-N products. Many of these issues were resolved in draft 2.0 that was proven to be a more robust version of the standard. Draft 2.0 mandates 20 MHz channels (40 MHz optional), one spatial stream for clients and two spatial streams for access points. In May 2007 the Wi-Fi Alliance announced the first 802.11 pre-N certifications compliant and interoperable to draft 2.0 based on products from industry leaders Atheros, Broadcom, Cisco, Intel, Marvell and Ralink which eventually included products from Belkin, Linksys and Netgear. Certification to draft 2.0 specifies 20 MHz channels, mixed-mode operation, where every 802.11n transmission is embedded with in an 802.11b and 802.11g transmission. In March 2008, TGn adopted draft 3.0 and TGn is on track to complete the standard late 2009.

One very interesting fact about 802.11n is that it is the first major WLAN standards development that had no significant FCC regulatory issues during its development timeframe that were driving the committee's technology decisions.

In March 2007 the IEEE 802.11 approved the formation of a “Very High Throughput Study Group” (VHT-SG) to explore extending WLAN data rates beyond current 802.11n data rates to Giga-bit (> 1Gb/s) rates, with the goal of creating a new amendment project and task

**Figure 12** Airgo 802.11 “pre-N” MIMO reference design

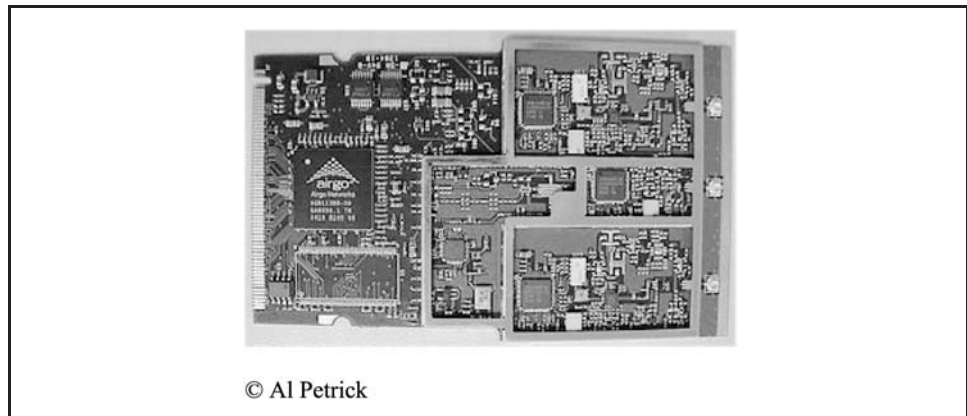

group under the 802.11 working group by November 2008. From July 2007 through March 2008 industry leaders within VHT-SG including Broadcom, Intel, Motorola, Network Networks, Qualcomm and members of the Wi-Fi Alliance interacted in defining market usage models and what is required to achieve Giga-bit data rates with current radio technology and future technology looking forward beyond 2010.

In September 2007 frequency spectrum including 6 GHz, 60 GHz and even above 300 GHz were considered as possibilities for operation by VHT-SG. In March 2008, VHT-SG decided to focus on 6 GHz and 60 GHz as distinct possibilities for next generation WLANs. VHT-SG is leaning towards using single carrier modulation and multi-carrier (OFDM) modulations similar to the technologies used in 802.11n and legacy 802.11b/g devices. The unlicensed 60 GHz band offers 5 GHz of total bandwidth under current FCC rules and is specified for operation for such wireless devices such as WPANs (wireless personal area networks). However at 60 GHz there is significant path loss due oxygen absorption in the atmosphere which is a major challenge to overcome in terms size, cost and power consumption. Many members of VHT-SG believe radios operating at these frequencies will have significantly limited range to <30 feet for in-room communications and find it challenging to meet the range requirements of WLANs systems today. SiBeam a startup company has developed the worlds-first WPAN for task group 802.15.3c operating at 60 GHz. SiBeam has the challenge to prove its technology is applicable beyond WPANs to WLANs. VHT-SG is on track become a task group later in 2008. What's certain is that as the 802.11 working group progresses in the development of Giga-bit WLANs, ensuring FCC regulatory compliance, if not asking for new regulations, will likely be a key part of the process.

## 8. Concluding remarks

The conclusion that the authors draw from this description of the WLAN industry is probably apparent to anyone with the fortitude to have read all the way to the end. Less is more when it comes to setting rules for unlicensed spectrum access. Focus on the transmitters only and do not try to pick winners or “protect” consumers from substandard or inefficient receivers. The marketplace will easily sort out the high value usage of the spectrum from the low value. If a cordless phone interferes badly with a WLAN (or vice versa), a consumer will soon decide amongst getting rid of one of them, not using them both at the same time, buying a single system that does both, or buying another system that avoids the interference. Consumers will always whip industry into shape on such “problems” far more efficiently than government ever can.

The most sweeping technology change of our time in wireless communications is the advance of spatial processing (or “smart antennas”). The existing unlicensed band rules do not generally discriminate against spatial processing but neither do they enable the maximum possible benefits. The advent of spatial processing can bring us far greater usage and co-existence of disparate systems in unlicensed bands than we have today. 802.11n is only a first step and the technology is applicable to applications such as RFID as well. Thus, one area where future rulemaking in the unlicensed bands could create more value is to permit temporal increases in spatial power density so long as average power densities are maintained. This is analogous to frequency hopping which has never had any minimum channel bandwidth – in other words, one can have very high instantaneous power density in the frequency dimension so long as the average power density is limited by uniformly using many hopping channels. Think spatial “bandwidth” instead of frequency “bandwidth” and the analogy becomes clear.

Finally, the authors wish to thank the FCC and everyone in the WLAN industry for the tremendous progress we have all achieved collectively to date. Who among us, in say 1990, could have realistically predicted that today there would be one billion devices in the 2.4GHz band affecting the daily lives of normal people everywhere. Well, perhaps microwave oven manufacturers might have, but probably not those few crazies back then in the WLAN industry with respect to their own industry's products! This is a job well done by all involved. It has been our honor and privilege to work with all of you.

## About the authors

Kevin J. Negus (M'88) was born in Fredericton, Canada in 1961. He received the BAsC, MASc and PhD degrees in Engineering from the University of Waterloo in Canada in 1984, 1985 and 1988 respectively.

From 1988 to 1998 he held various R&D management positions with the Hewlett-Packard Company, where he led the development of RF chipset solutions for systems such as GPS, GSM, IS-54, IS-95, DECT and 802.11. From 1998 to 2002, he was the Chief Technology Officer of the Proxim Corporation in Sunnyvale, CA, where he was responsible for core technology strategy including silicon development, acquisitions, standards participation and intellectual property licensing. He has published more than 40 technical papers and holds several US patents. His base office is in Hyattville, Wyoming where he and his wife Eva run a working cattle ranch. He is currently a General Partner with Camp Ventures in Los Altos, CA (a venture capital investment firm specializing in early-stage technology start-up companies), a management advisor to SiTime and Mojix, and a consultant on IP litigation matters to multiple clients. He was also formerly a member of the FCC's Technical Advisory Committee, a member of the Wyoming State Telecommunications Council, Executive Chairman of WiDeFi (acquired by Qualcomm in October 2007), and a management advisor to several successful start-ups including Resonext Communications (acquired by RF Micro Devices in December 2002), Athena Semiconductor (acquired by Broadcom in October 2005), and Quorum Communications (acquired by Spreadtrum in January 2008).

He was awarded the IEEE "Best Paper" Award for a 1989 IEEE journal article based on his PhD research. He has also won the University of Waterloo Gold Medal Award for best academic achievement university-wide during his time in the graduate school program. Kevin J. Negus is the corresponding author and can be contacted at: [kevin@tctwest.net](mailto:kevin@tctwest.net)

Al Petrick was born in Wilkes-Barre, PA, USA, in 1957. He received the BS degree in Electrical Engineering in 1980, from Rochester Institute of Technology in Rochester, New York and a Master's degree in Business Administration in 1997 from Rollins College in Winter Park, Florida and in 1997 studied business strategies at Northwestern University. From 1980 through 1993 he held various engineering RF modem and DSP systems and circuit design positions with Racal Milgo, Lockheed-Martin, and Mnemonics. From 1993 to 1999 he held senior management positions at Harris Semiconductor in strategic marketing, where he was responsible for product strategy of wireless semiconductor products, and WLAN standards which led to the development of the world's first 802.11b chipset known as PRISM. From 1999 through 2007 he held Vice-President of Business Development positions at ParkerVision, IceFyre Semiconductor and WiDeFi. He has been an active participant in the development of IEEE 802 standards since 1994. He has been Vice-Chairman IEEE 802.11 Working Group for the past eight years and is Chairman of the 802.11 Maintenance Task Group. He co-authored several patents and co-authored an industry leading textbook on the IEEE 802.11 standard titled: *IEEE 802.11 Handbook, A Designer's Companion* published by IEEE. He is a wireless consultant at Jones-Petrick and Associates located in Orlando, Florida and is a member of several technical advisory boards.

---

To purchase reprints of this article please e-mail: [reprints@emeraldinsight.com](mailto:reprints@emeraldinsight.com)  
Or visit our web site for further details: [www.emeraldinsight.com/reprints](http://www.emeraldinsight.com/reprints)